



Operating instructions

Temperature differential controller

3 inputs, 1 output

These operating instructions are part of the product.

- ▶ Read these operating instructions carefully before use,
- ▶ keep them over the entire lifetime of the product,
- ▶ and pass them on to any future owner or user of this product.



Contents

1 About this manual	3	6 Commissioning	19
1.1 Applicability	3	7 Description of controller functions	20
1.2 Users.....	3	7.1 Automatic storage tank charging..	20
1.3 Description of symbols	4	7.2 Maximum storage tank temperature.....	21
2 Safety	5	7.3 Maximum collector temperature...	21
2.1 Proper usage	5	7.4 Tube collector function	21
2.2 Improper usage.....	5	7.5 Holiday function	22
2.3 Dangers during installation and commissioning.....	6	7.6 Anti-freeze function	23
2.4 Detecting faults.....	7	8 Operation	24
2.5 Exclusion of liability.....	7	8.1 Reading temperature values.....	24
3 Description	9	8.2 Setting the controller.....	24
3.1 Controller in the solar circuit	9	9 Maintenance	29
3.2 Casing overview	11	9.1 Fault causes.....	29
4 Installation	12	9.2 Testing the temperature sensors....	33
4.1 Opening/closing the casing	12	10 Dismantling and disposal	35
4.2 Mounting	13	11 Legal guarantee	36
4.3 Electrical connection	14	12 Technical data	37
5 Display overview	18		

1 About this manual

1.1 Applicability

This manual describes the installation, commissioning, operation, maintenance and dismantling of the temperature differential controller for solar thermal energy systems. When installing the remaining components, e.g. solar collectors, pump assemblies, storage units, pumps and switching valves, be sure to observe the appropriate installation instructions provided by each manufacturer.

1.2 Users

Installation, commissioning, maintenance and dismantling of the controller may only be performed by trained professional personnel. Before commissioning, the controller must be professionally assembled and installed by professional personnel in accordance with the applicable regional and transregional regulations as well as the safety instructions and general instructions within these installation and operating instructions. The professional personnel must be familiar with these operating instructions.

The controller is maintenance-free.

Use the controller only after first thoroughly reading and understanding this instruction manual and the safety instructions. Adhere to all safety instructions. In the event of any ambiguities regarding the operation

and alteration of parameters or functions, consult professional personnel.

1.3 Description of symbols



1.3.1 The structure of the warning notices

SIGNAL WORD

Type, source and consequences of the danger!

- Measures for avoiding danger.

1.3.2 Danger levels in warning notices

Danger level	Likelihood of occurrence	Consequences resulting from non-compliance
 DANGER	Imminent threat of danger	Death, serious bodily injury
 WARNING	Possible threat of danger	Death, serious bodily injury
 CAUTION	Possible threat of danger	Minor bodily injury
CAUTION	Possible threat of danger	Property damage

1.3.3 Notes

NOTE

Note on easier and safer working habits.

- Measures for easier and safer working habits.

1.3.4 Other symbols and markings

Symbol	Meaning
✓	Precondition for action
▶	Call to action
⇒	Result of action
•	List
Emphasis on issue at hand	Emphasis on issue at hand

2 Safety

2.1 Proper usage

The temperature differential controller (called controller in the following) may only be used for controlling solar thermal systems within the permissible ambient conditions (see chapter 12).

2.2 Improper usage

The controller must not be operated in the following environments:

- outdoors
- in damp rooms
- in rooms where highly flammable gas mixtures can occur
- in rooms in which the operation of electrical and electronic components may cause dangers to arise

2.3 Dangers during installation and commissioning

The following dangers exist during installation / commissioning of the controller and during operation (in case of installation errors):

- Risk of death by electrocution
- Risk of fire due to short-circuit
- Damage to any of the constructional fire safety measures present in the building due to incorrectly installed cables
- Damage to the controller and connected devices due to improper ambient conditions, inappropriate power supply and connecting prohibited devices or faulty devices and incorrect assembly or installation

Therefore, all safety regulations apply when working on the mains supply. Only electricians may perform work that requires opening the controller (such as electrical connection work).

- ▶ When laying cables, ensure that no damage occurs to any of the constructional fire safety measures present in the building.
- ▶ Make sure that the permissible ambient conditions at the installation site are not exceeded (see chapter 12).
- ▶ Be sure to comply with the specified protection degree.
- ▶ Factory labels and markings may not be altered, removed or rendered unreadable.

- ▶ Before connecting the device, make sure that the power supply matches the specifications on the type plate.
- ▶ Make sure that all devices which are connected to the controller conform to the technical data of the controller.
- ▶ Secure the device against unintentional start-up.
- ▶ All work on an open controller must be performed with the mains supply disconnected.
- ▶ Protect the controller against overloading and short-circuiting.

2.4 Detecting faults

- ▶ Check the display regularly.
- ▶ In case of faults, isolate the cause (see chapter 9).
- ▶ As soon as it becomes evident that safe operation is no longer possible (e.g. visible damage), remove the device from the mains supply immediately.
- ▶ Have professional personnel remedy the fault.

2.5 Exclusion of liability

The manufacturer cannot monitor the compliance with this manual or the conditions and methods during the installation, operation, usage and maintenance of the controller. Improper installation of the system may result in damage to property and, as a result, to bodily injury.

Therefore, we assume no responsibility and liability

for loss, damage or costs which result from or are in any way related to incorrect installation, incorrect execution of installation work, improper operation and incorrect usage and maintenance.

Similarly, we assume no responsibility for patent right or other right infringements of third parties caused by usage of this controller.

The manufacturer reserves the right to make changes to the product, technical data or installation and operating instructions without prior notice.

3 Description

3.1 Controller in the solar circuit

3.1.1 The purpose of the controller

The controller controls the solar thermal system

3.1.2 The structure of the solar circuit

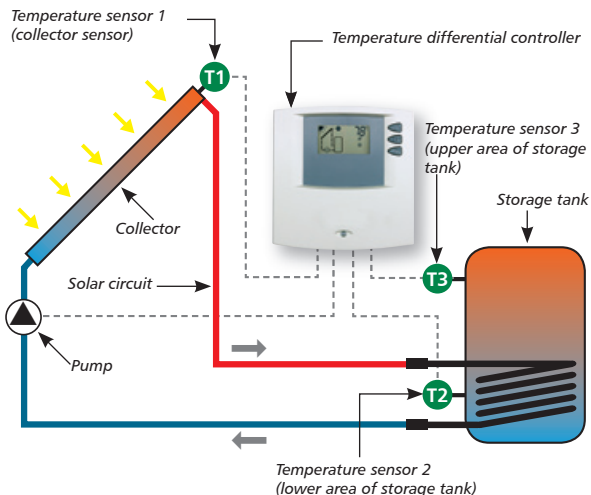

3.1.3 The function of the solar circuit

The controller constantly compares the temperatures between the collector (T_1) and the lower area of the storage tank (T_2). Once the sun heats the collector and there is a temperature difference of 8 K between the collector and the storage tank, the pump is switched on.

The pump extracts the heat transfer fluid from the lower cooler area of the storage tank and pumps it to the collector. The heat transfer fluid in the collector is heated by the sun and flows back to the storage tank.

The heat transfer fluid heats the domestic water via a heat exchanger located in the storage tank.

3.2 Casing overview

Operating switch

The following modes of operation can be selected:-

On
for commissioning
and testing for function-

Automatic
for automatic operation

- **Off**
to switch-off the pumps

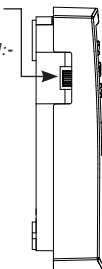

Display

graphic display, animated, for controller operation and system settings



Operating buttons

◀ Arrow up
◀ SET button
◀ Arrow down

Connections

Pump, mains grid, temperature sensor

4 Installation

4.1 Opening/closing the casing

DANGER

Risk of death by electrocution!

- ▶ Remove the controller from the power supply before opening the casing.
- ▶ Make sure that the power supply cannot be unintentionally switched on.
- ▶ Do not damage the casing.
- ▶ Only switch the power supply back on after the casing has been closed.

The upper casing is connected to the lower casing by two latches, and fastened with a screw.

4.1.1 Opening the casing

- ▶ Loosen the screw and remove the upper casing in an upwards direction.

4.1.2 Closing the casing

- ▶ Place the upper casing over the lower casing at an angle. Insert the latches into the recesses of the lower casing.
- ▶ Pivot the upper casing down and feed the operating buttons through the matching holes.
- ▶ Fasten the casing tightly with the screw.

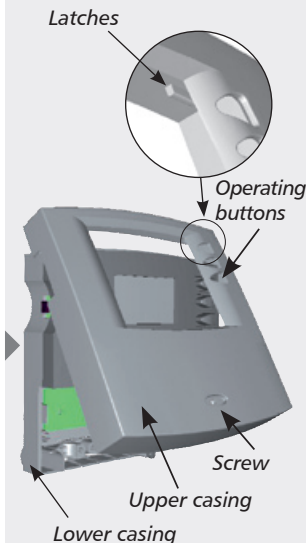

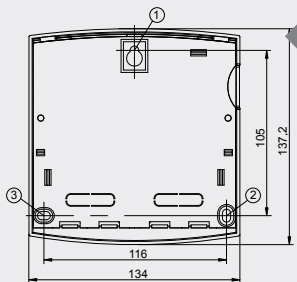

4.2 Mounting

WARNING

Risk of electrical shock and fire if mounted in a damp environment!

- ▶ Only assemble the controller in an area where the degree of protection is sufficient.

4.2.1 Mounting the controller

CAUTION

Risk of injury and damage to the casing when drilling!

- ▶ Do not use the casing as a drilling template.
- ▶ Choose a suitable installation site.
- ▶ Drill the upper fastening hole.
- ▶ Screw in the screw.
- ▶ Remove the upper casing.
- ▶ Hang the casing in recess ①.
- ▶ Mark the position of the lower fastening holes ②,③.
- ▶ Remove the casing again.
- ▶ Drill the lower fastening holes.
- ▶ Hang the casing in recess ①.
- ▶ Screw the casing firmly using the lower fastening holes ② and ③.
- ▶ Mount the upper casing.

4.3 Electrical connection

WARNING

Risk of death by electrocution!

- ▶ Remove the controller from the power supply before opening the casing.
 - ▶ Observe all guidelines and regulations of the local electricity supplier.
-

NOTE

The device is to be connected to the grid by means of a plug with grounding contact, or in the case of a fixed electrical installation via a disconnection device for complete disconnection in accordance with the installation guidelines

4.3.1 Preparing the cable feed

Depending on the type of installation, the cables may enter the device through the rear of the casing or the lower side of the casing.



Feeding the cable through the rear of the casing (diagram 1):



⚠ WARNING

Risk of electrical shock and fire due to cables coming loose!

- ▶ Install an external strain relief for the cables.
- ▶ Remove the plastic flaps ⑦ from the rear side of the casing using an appropriate tool.

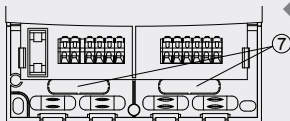

Diagram 1: Cable feed from the rear

Feeding the cable through the lower side of the casing (diagram 2):



⚠ WARNING

Risk of electrical shock and fire due to cables coming loose!

- ▶ Fasten the flexible cabling to the casing using the strain-relief clamps provided.
- ▶ Cut the left and right plastic flaps ⑥ using an appropriate tool and break them out of the casing.

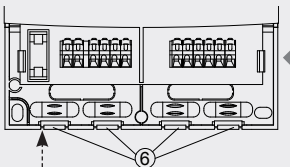

Diagram 2: Cable feed from below

4.3.2 Connecting the cables

- ▶ If a protective conductor is provided or required for the pump, connect it to the controller terminals. When connecting the protective conductor, observe the following points:

- Make sure that the grounding contact is also connected to the controller's mains supply side.
- Each terminal may only be connected to a single connecting wire (max 2.5 mm²).
- The terminals are suitable for connection without sleeves; stranded wires are to be twisted (1 twist per 20 mm).
- ▶ Only use the original temperature sensors (Pt1000) that are approved for use with the controller.
- ▶ Observe the following points:
 - The polarity of the sensor contacts is not important.
 - Do not lay sensor cables close to 230 volt or 400 volt cables (minimum separation: 100 mm).
 - If inductive effects are expected, e.g. from heavy current cables, overhead train cables, transformer substations, radio and television devices, amateur radio stations, microwave devices, etc. then the sensor cables must be adequately shielded.
 - Sensor cables may be extended to a maximum length of 100 m.
- ▶ When using extension cables, select the following cable cross sections:
 - 0.75 mm² up to 50 m long
 - 1.5 mm² up to 100 m long
- ▶ Connect the cables in accordance with the terminal plan.

4.3.3 Terminal plan

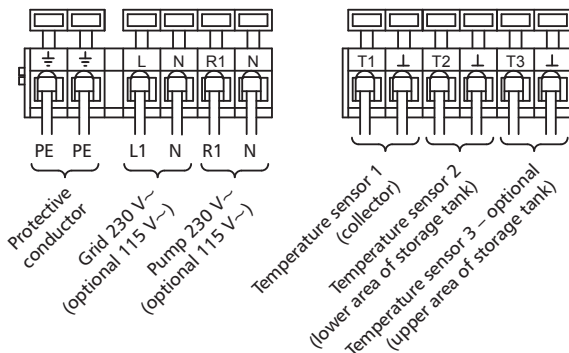

4.3.4 Actuating the connecting terminals

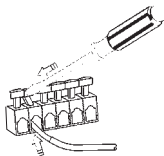

NOTE

The connecting terminal may only be actuated with an appropriate tool. An unsuitable tool or too much mechanical pressure can damage or even destroy the connecting terminal.

5 Display overview

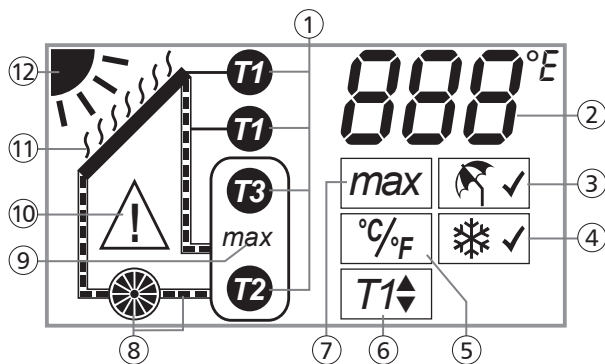

- ① Temperature sensor symbols
- ② Display for temperature values and fault symbols, e.g. short circuit, interruption (see page 30) or SYS = system error (see page 39)
- ③ Holiday function (see pages 22/23)
- ④ Anti-freeze function (see page 23)
- ⑤ Setting the temperature unit °C / °F ⑥ tube collector function
- ⑦ Setting the maximum storage tank temperature
- ⑧ Solar circuit symbols
- ⑨ Displays message "Maximum storage tank temperature has been reached"
- ⑩ Warning display if faults occur, e.g. short circuit, interruption (see page 30) or SYS = system error (see page 31)
- ⑪ Displays message for evaporation of the collector fluid
- ⑫ Displays message for "Sufficient heat supply"

6 Commissioning

6.1 Testing the pump

CAUTION

Damage to pump caused by dry operation!

- ▶ Make sure that the solar circuit is filled with heat transfer fluid.

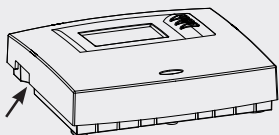

- ✓ The controller casing is closed
- ✓ All connections are properly made.
- ✓ The solar energy system is filled.
- ▶ Connect the mains supply.
- ▶ To switch on the pump, set the operating switch to the upper position (on).
 - ⇒ *The display is backlit in red*
 - ⇒ **on** appears in the display. After approx. 3 seconds **on** flashes in alternation with the display.

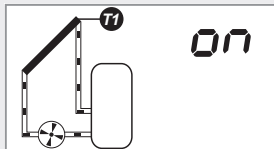

- ▶ To switch off the pump, set the operating switch to the lower position (off).
 - ⇒ *The display is backlit in red*
 - ⇒ **off** appears in the display. After approx. 3 seconds **off** flashes in alternation with the display.

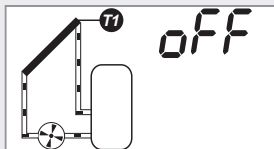

CAUTION

The incorrect operating mode may cause the system to shut down or impair proper functioning!

- ▶ After testing the pump, always set the operating switch to automatic operation.
- ▶ To set the controller to automatic operation, move the operating switch to the middle position (Auto).
 - ⇒ "Aut" is shown on the display for approx. 3 seconds.

7 Description of controller functions

7.1 Automatic storage tank charging

The controller constantly compares the temperatures between the collector (T1) and the lower area of the storage tank (T2). As soon as the temperature in the collector (T1) is 8 K (constant fixed value) higher than the temperature in the storage tank (T2), the following display appears:

- The sun symbol is displayed

If no safety limits prohibit the pump from operating, the pump is switched on. The following display appears:

- The pump symbol rotates

If the temperature difference falls below 4 K (constant fixed value), the pump is switched off. The sun symbol is no longer shown on the display.

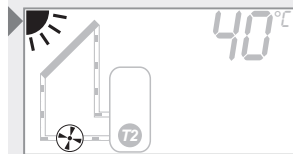

7.2 Maximum storage tank temperature

- If the lower area of the storage tank (T2) reaches the set maximum storage tank temperature (factory setting 60 °C), charging is stopped. A temperature of 3 K below the maximum storage tank temperature must first be reached before charging can be resumed. The following displays appear: The pump symbol does not move
- The sun symbol is displayed
- The **max** indication flashes in the storage tank symbol

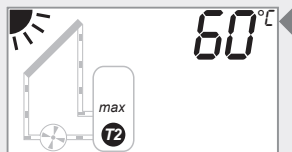

7.3 Maximum collector temperature

During periods of high solar irradiance, the temperature (T1) of the heat transfer fluid can exceed 130°C. The heat transfer fluid evaporates. In this case, the pump is stopped for protection purposes until the temperature drops below 127°C.

The following displays appear:

- The pump symbol does not move
- The sun symbol is displayed
- The vapour symbol flashes

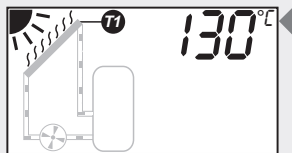

7.4 Tube collector function

For reasons of construction the collector temperature (T1) can only be imprecisely recorded with vacuum tube collectors (in many cases there are no immersion sensors; the sensor is outside the collector pipe). In

these cases, the solar circuit must be briefly activated at regular intervals to transmit the actual heat from the collector pipe to the sensor (T1). If the tube collector function is activated, the controller automatically switches the pump on every 30 minutes for 30 seconds.

The following display appears:

- The lower temperature sensor, T1, is shown.

7.5 Holiday function

The holiday function is used to cool down a completely heated storage tank again via the collector. The storage tank can heat up too much, e.g. if no hot water is extracted from the storage tank over an extended period of time (holiday) of intense solar irradiance. A completely heated storage tank subjects the solar energy system to a higher thermal load and the solar fluid can evaporate.

If the holiday function is activated, the storage tank is cooled as follows: If the temperature in the storage tank rises to 10 K below the set storage tank maximum temperature, the controller attempts to discharge the lower section of the storage tank to 35°C (e.g. at night). To do so, the pump is automatically switched on once the collector is 8 K colder than the storage tank. Once the temperature difference between the collector and the storage tank is only 4 K, the pump is switched off again.

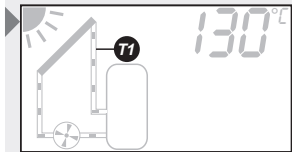

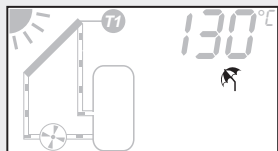

The following display appears:

- The holiday symbol is displayed

7.6 Anti-freeze function

If the anti-freeze function is activated, the controller switches the pump on as soon as the collector temperature T1 falls below +5 °C. The heat transfer fluid is then pumped through the collector in an attempt to prevent the system from freezing. If the collector reaches a temperature of +7 °C, the pump is switched off again.

CAUTION

The solar energy system can freeze despite the activated anti-freeze function!

During a power outage, the anti-freeze function does not operate.

During long-term periods of frost (due to restricted water tank heat storage).

If collectors are mounted in locations exposed to wind.

- It is recommended to generally use heat transfer fluid with anti-freeze for solar energy systems.

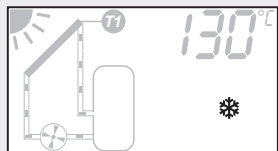

Standard anti-freeze heat transfer fluids for solar energy systems also contain an additional corrosion inhibitor.

The following display appears:

- The anti-freeze symbol is displayed

8 Operation

CAUTION



The incorrect operating mode may cause the system to shut down or impair proper functioning!

- ▶ Make sure that the operating switch is set to automatic operation.

8.1 Reading temperature values



NOTE

The temperature in the above storage tank is only displayed if the temperature sensor T3 (not included in delivery) is also connected.

- ▶ Use the buttons  and  to select temperature sensor (T1, T2, T3).
- ⇒ *The selected temperature sensor and the current temperature reading appear in the display.*

8.2 Setting the controller

8.2.1 Menu operation

- ▶ To open the Settings menu, press the  button for approx. 2 seconds.
- ⇒ *The current storage tank maximum temperature is displayed.*
- ⇒ *Symbol for the T2 temperature sensor and max flash.*
- ▶ To switch to the next setting, press the  or  button.

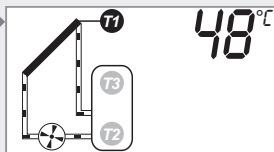

- ▶ To exit the Settings menu, press the  button again until the menu is no longer displayed.





8.2.2 Setting the storage tank maximum temperature

CAUTION

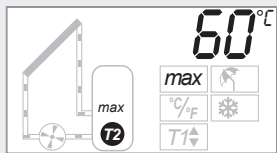
Risk of scalding by excessive domestic water temperature!



- ▶ Set the storage tank max. temperature no higher than 60°C.
- ▶ Install a thermostatic mixer in the hot water pipe and set to max. 60°C.

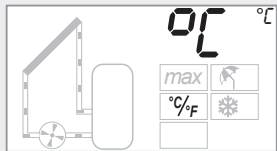

- ✓ The menu is open
- ▶ Press the  button for approx. 2 seconds until the storage tank maximum temperature flashes.
- ▶ Change the storage tank maximum temperature using the  or  buttons.
- ▶ To save the value, press the  button.

8.2.3 Selecting the temperature unit





- ✓ The menu is open
- ▶ Press the  button again until °C / °F flashes.
- ▶ Press the  button for approx. 2 seconds until the desired temperature unit – °C or °F – flashes.

8.2.4 Activating the tube collector function

NOTE

Incorrectly setting the controller can compromise the efficiency of the solar energy system. Therefore, only activate the tube collector function if the construction of the collector does not allow its temperature to be recorded immediately and/or accurately (in some cases there are no immersion sensors; the sensor is outside the collector pipe).

- ✓ The menu is open
- ▶ Press the  button again until the symbol for T1 flashes.
- ▶ Press the  button for approx. 2 seconds until the symbol for T1 switches from the upper to the lower position.

8.2.5 Activating/deactivating the holiday function



NOTE

Incorrectly setting the controller can compromise the efficiency of the solar energy system.

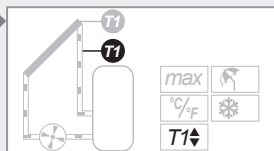
- ▶ Only activate the holiday function if you intend to be absent for an extended period.
- ▶ Deactivate it again upon your return.

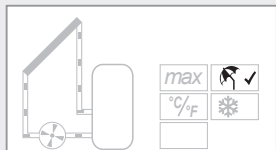



- ✓ The menu is open
- ▶ Press the  button until the holiday symbol flashes.
- ▶ Press the  button for approx. 2 seconds until the small tick on the holiday symbol appears/goes out.

8.2.6 Activating/deactivating the anti-freeze function

CAUTION

The solar energy system can freeze despite the activated anti-freeze function!

During a power outage, the anti-freeze function does not operate.



During long-term periods of frost, the system can freeze despite the anti-freeze function.

- ▶ If frost is expected for a long period of time, only operate the system with anti-freeze.

NOTE

Incorrectly setting the controller can compromise the efficiency of the solar energy system.

- ▶ Only activate the anti-freeze function for solar energy systems that are not filled with anti-freeze.

- ✓ The menu is open
- ▶ Press the  button until the anti-freeze symbol flashes.
- ▶ Press the  button for approx. 2 seconds until the small tick on the anti-freeze symbol appears/goes out.

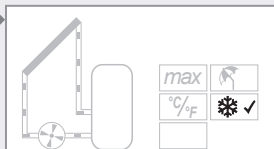

9 Maintenance

The controller was conceived for years of continuous trouble-free operation. Nevertheless, faults may occur. Maintenance may only be performed by professional personnel.

In most cases, however, the fault does not lie with the controller, but rather with the peripheral components. The following description covers the most common problems encountered with the controller.

- ▶ Only send in the controller, with a precise fault description, if none of the following faults are present.

9.1 Fault causes



WARNING

Risk of death by electrocution!

- ▶ Remove the controller from the power supply before opening the casing.

Controller does not appear to function at all.

Secondary symptoms	Possible cause / remedy
The controller display is blank.	No power supply present ▶ Have professional personnel check the fuse and the supply cable.

The pump, which is connected to the controller, is not running, although its switch-on conditions have been fulfilled.

Secondary symptoms	Possible cause / remedy
The pump symbol rotates in the display.	<p>The pump connecting cable is not connected, interrupted or the fuse in the controller is burned out.</p> <p>► If necessary, have professional personnel replace the fuse. (Replacement fuse is located in the casing).</p>
<ul style="list-style-type: none"> • The pump symbol does not rotate • The display is backlit in red • OFF flashes 	<p>Operating switch is set to manual</p> <p>► Set the operating switch to automatic operation.</p>
<ul style="list-style-type: none"> • The pump symbol does not rotate • The display is backlit in yellow • Evaporation symbol or max are flashing 	<p>No fault.</p> <p>The system has stopped because maximum collector temperature or maximum storage tank temperature have been reached.</p>

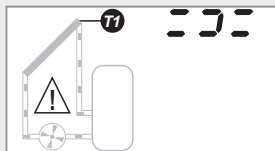

Short-circuit symbol and warning display appear.

Secondary symptoms	Possible cause / remedy
<ul style="list-style-type: none"> The pump symbol does not rotate Display background alternately flashes red and yellow 	<p>Temperature sensor or its supply cable short-circuited</p> <ul style="list-style-type: none"> Have professional personnel check the supply cables of the temperature sensors and that they are correctly connected to the controller.

NOTE

In case of a T3 short-circuit the pump does not stop.

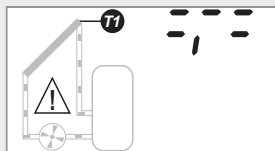

Interruption symbol and warning signal appear

Secondary symptoms	Possible cause / remedy
<ul style="list-style-type: none"> The pump symbol does not rotate Display background alternately flashes red and yellow 	<p>Temperature sensor T1 or T2 or its supply cable is interrupted</p> <ul style="list-style-type: none"> Have professional personnel check the supply cables of the temperature sensors and that they are correctly connected to the controller.

NOTE

If T3 is interrupted no message appears

SYS flashes in the controller display

Possible cause / remedy

SYS means there is a system error. This means that despite the pump running, a temperature difference exceeding 80 K between the collector and the storage tank was recorded.

The following causes are possible:

- The pump is faulty or not correctly connected
- The isolating valve in the solar circuit is still closed
- Air is in the solar circuit

Since a standard circulation pump cannot eliminate air bubbles inside the piping system, the heat transfer medium circuit comes to a standstill.

- ▶ Have professional personnel check the solar system to prevent damage.
- ▶ Once the fault has been remedied, press any button to acknowledge the fault message.

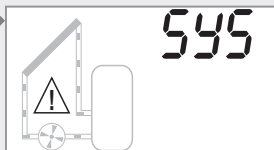

9.2 Testing the temperature sensors

9.2.1 Safety

Only professional personnel may test the temperature sensors.

9.2.2 Testing the resistance values

DANGER

Risk of death by electrocution!

- ▶ Remove the controller from the power supply before opening the casing.
-

The temperature is recorded by resistance sensors. These are PT1000 temperature sensors. Depending on the temperature, the resistance value also changes. A potentially defective sensor can be checked using an ohmmeter.

Measuring resistance values

- ▶ Disconnect the relevant temperature sensor from the controller.
- ▶ Measure the resistance value. The typical resistance values, depending on the temperature, are listed in the following table. Please note that small deviations are permissible.



Temperature sensor resistance values

Temperature [°C]	-30	-20	-10	0	10	20
Resistance [Ω]	882	922	961	1000	1039	1078

Temperature [°C]	30	40	50	60	70	80
Resistance [Ω]	1117	1155	1194	1232	1271	1309

Temperature [°C]	90	100	110	120	130	140
Resistance [Ω]	1347	1385	1423	1461	1498	1536

Temperature [°C]	150	160	170	180
Resistance [Ω]	1573	1611	1648	1685



10 Dismantling and disposal

DANGER

Risk of death by electrocution!

- ▶ Remove the controller from the power supply before dismantling it.
-
- ▶ To dismantle the controller, follow the assembly instructions in the reverse order.
 - ▶ Dispose of the controller in accordance with the regional regulations.

11 Legal guarantee

In accordance with German statutory regulations, there is a 2-year legal guarantee on this product for the customer.

The seller will remove all manufacturing and material faults that occur in the product during the guarantee period and affect the correct functioning of the product. Natural wear and tear does not constitute a malfunction. No legal guarantee can be offered if the fault can be attributed to third parties, unprofessional installation or commissioning, incorrect or negligent handling, improper transport, excessive loading, use of improper equipment, faulty construction work, unsuitable construction location or improper operation or use. Legal guarantee claims shall only be accepted if notification of the fault is provided immediately after it is discovered. Guarantee claims are to be directed to the seller.

The seller must be informed before guarantee claims are processed. For processing a guarantee claim an exact fault description and the invoice / delivery note must be provided.

The seller can choose to fulfil the legal guarantee either by repair or replacement. If the product can neither be repaired nor replaced, or if this does not occur within a suitable period in spite of the specification of an extension period in writing by the customer, the reduction in value caused by the fault shall be replaced, or, if this is

not sufficient taking the interests of the end customer into consideration, the contract is cancelled.

Any further claims against the seller based on this guarantee obligation, in particular claims for damages due to lost profit, loss-of-use or indirect damages are excluded, unless liability is obligatory by law.

12 Technical data

Temperature differential controller	
Operational voltage	230 V~ ($\pm 15\%$), 50 Hz [optional 115 V ($\pm 15\%$), 60 Hz]
Controller's own consumption	≤ 1 W
Inputs	3 temperature recording (Pt1000)
Output	1 switched output, switching performance max. 800 W [230 V~]
Display	Animated LCD display, 2-colour background
Protection degree	IP 20/DIN 40050
Permitted ambient temperature	0 to +45 °C
Mounting	wall-mounted
Weight	250 g
Casing	recyclable 3-piece plastic casing
Dimensions L x W x H [mm]	137 x 134 x 38
Temperature sensors 2 x Pt1000	1.5 m silicone cable (measuring range up to +180 °C)



709752